

# Engine Monitoring, Alarm & Control

## IMACS

Imacs is an Integrated Monitoring, Alarm and Control System for engines and machinery onboard ships. The system is comprised of Siemens PLC units in full redundancy, PC computers and powerful software. The comprehensive system provides integration of Power Management System, Tank level indication, Anti Heeling and Loading program in addition to the "standard" Engine Monitoring and automation features. Shore-side "Office" version with offline data and fault analysis is provided.

## System Highlights

- Use of Commercial Off The Shelf hardware eliminates the dependence on dedicated, more expensive and less accessible "marine" spare parts – enabling easy service and/or repair anywhere in the world.
- Fault finding and maintenance are very easy due to the SIMATIC-S7 PLC Push-Pull modules that can be replaced in no time.
- All work stations are connected by a common network and each station can take over the entire system regardless of other stations failure.
- Other computers on ship's LAN can log into the system at will (for monitoring only).
- Full redundancy of CPU and BUS – automatic take over if one PLC fails.
- Open architecture - easily fitted for every vessel.



## Software Features

- Online screen monitoring of all relevant information.
- Control of machinery (valves, pumps, generators etc.) from smart mimics.
- Graphical representation of data with time (Trend Analysis) for all variables.
- Easy setting of alarm set points and delay times, easy calibration of sensors by software.
- Critical operations are restricted by password to authorized personnel only.
- Logging and retrieval of data for long periods of time.
- Offline analysis of data from History files (Alarm statistics and Multi Sensor Analysis) - an excellent tool for easy preventive maintenance.
- "Office" version for shore supervision provides extensive offline analysis of both data and alarms (whole month data on CD-R or just "Last Hour File" by Email).
- On line Stability tests (GM Determination)

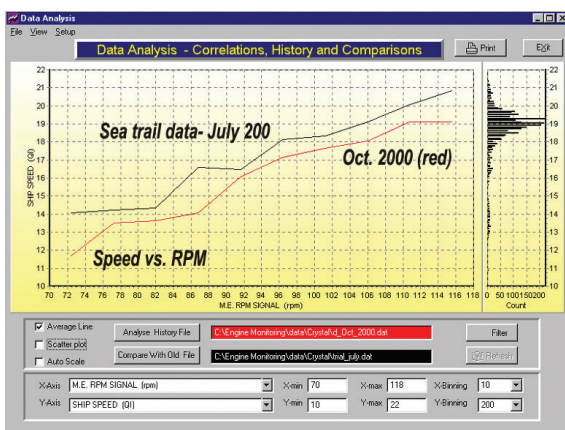

## Analysis Sample

ISRAEL:

HANEVIIM 6, RAMAT HASHARON 47279 ISRAEL T: (972) 3-5497295 F: (972) 3-7602722  
TOTEMPLS@TOTEMPLS.CO.IL

GERMANY:

HANDLESAGENTUR K. PASCHEN  
OFFICE@TXMARINE.COM

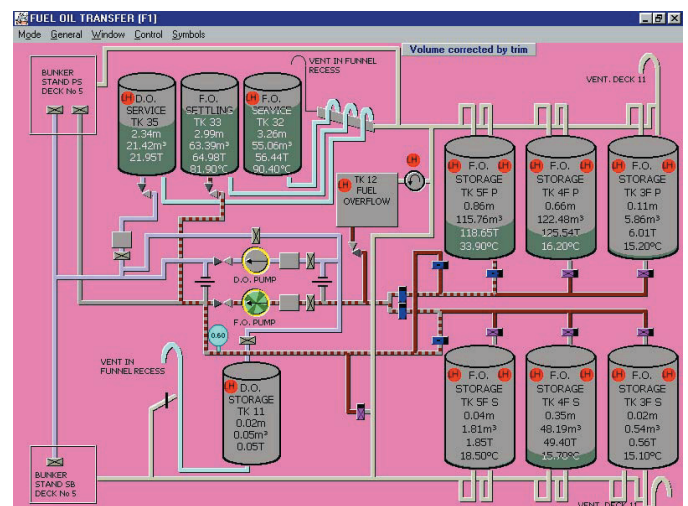

## Control Mimic Sample

**Totem Plus**

Where shipping meets high-tech

**TX Marine**  
HAMBURG

T: +49 41 21 4916890  
WWW.TXMARINE.COM